



(D) Montageanleitung

(GB) Assembly instructions

(FR) Notice de montage

(TR) Montaj talimatı

(IT) Istruzioni di montaggio

(NL) Handleiding voor de montage

(RU) Инструкция по монтажу

(CZ) Montážní návod

(HU) Szerelési útmutató

(RO) Instrucțiuni de montaj

(PL) Instrukcja montażu

(SK) Návod na montáž

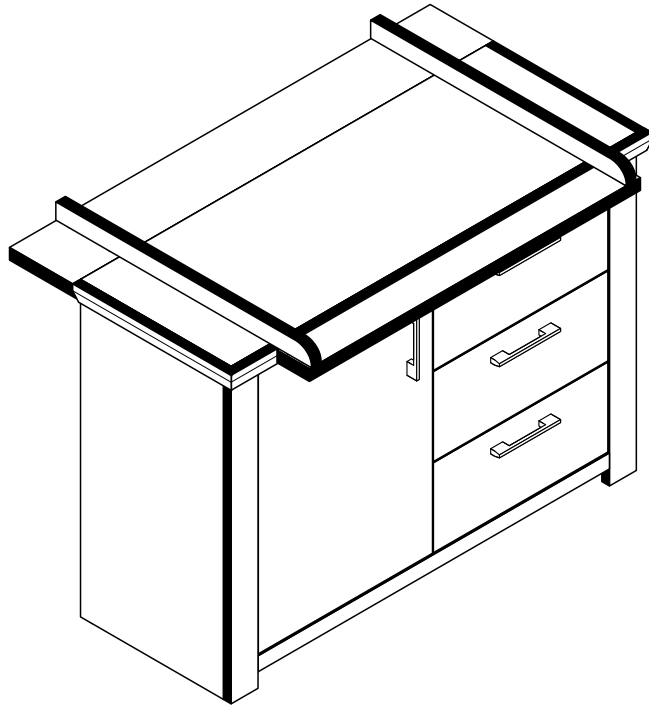

0442-Wiko_13 Wickelkommode

Service • Assistenza • Dienstverlening • Serwis
Servis • Szerviz • Сервисная служба

			<p>Colli 1/2 : (5) (8) (11) (15) (16) (17) (18) (19) (20) (21) (22) (23) (24) Beutel 1/3, 2/3, 3/3</p> <p>Colli 2/2 : (1) (2) (3) (4) (6) (7) (9) (10) (12) (13) (14) (25) (26) (27)</p>

Beutel 1/3

1-10 12x		6,3x50	1-30 24x		3x16	1-37 1x		4,5x25	1-70 6x		3x30	1-80 12x		3,5x13	1-90 4x		3,5x20
1-200 12x		6,3x13	1-329 8x		M4x22	2-08 12x		h=10mm	2-10 29x		h=12mm	2-20 41x		2-160 4x			
2-220 2x			8-80 1x														

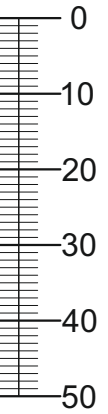

Beutel 2/3

3-07 1x		3-63 2x		3-64 2x	
------------	--	------------	--	------------	--

Beutel 3/3

3-130 8x		5-185 4x		5-190 2x		6-415 4x	
-------------	--	-------------	--	-------------	--	-------------	--

Colli 1/2

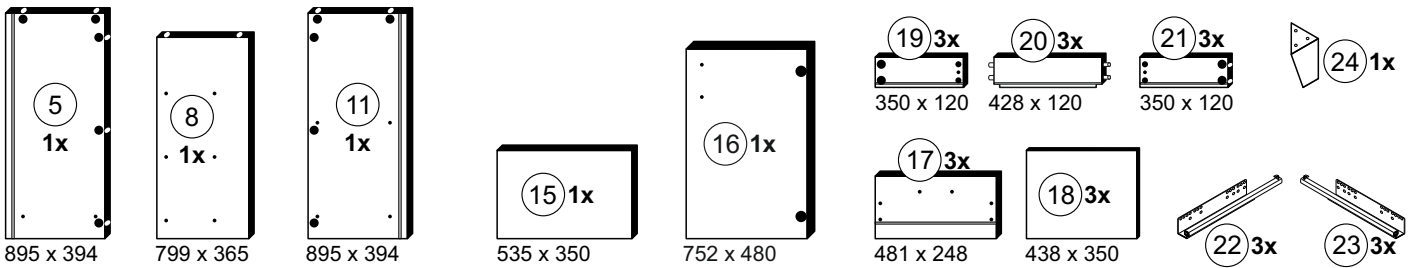

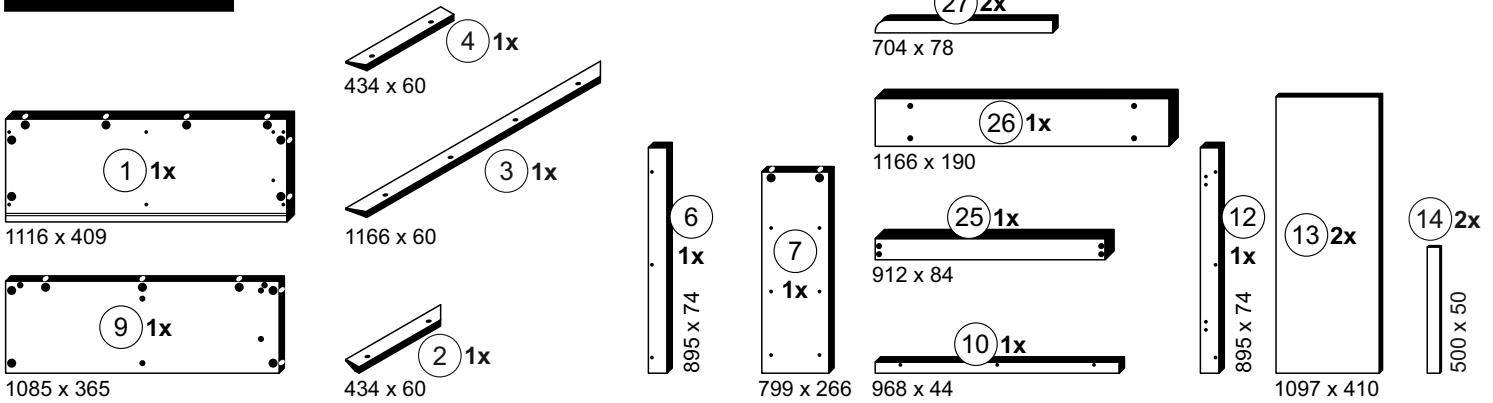

Colli 2/2

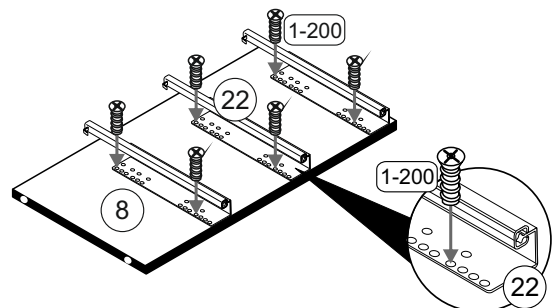
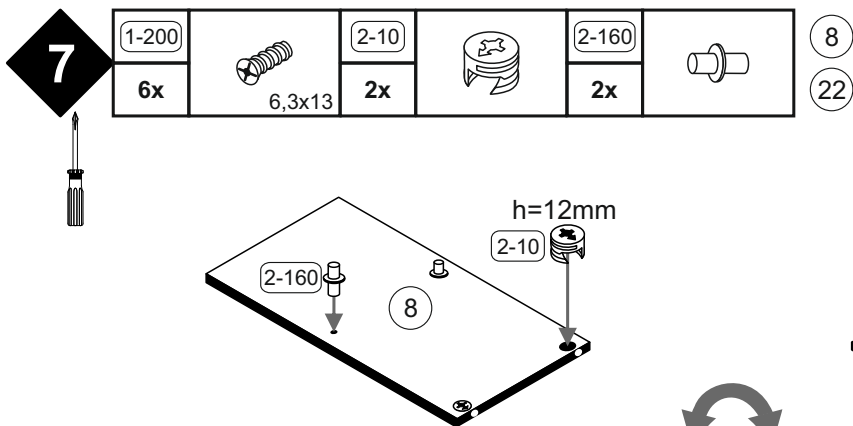
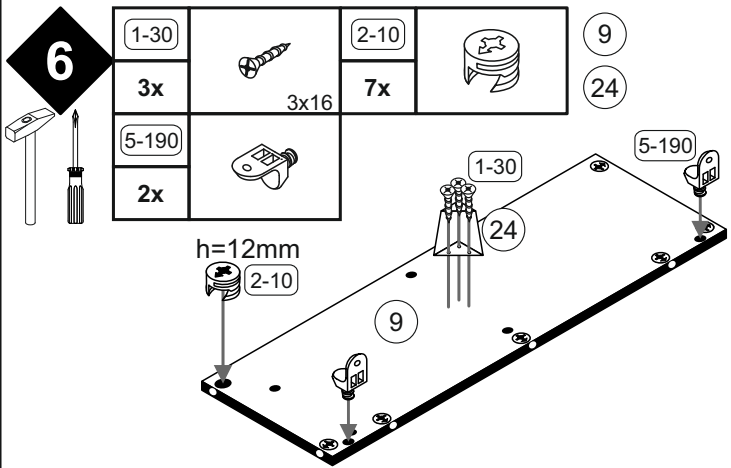
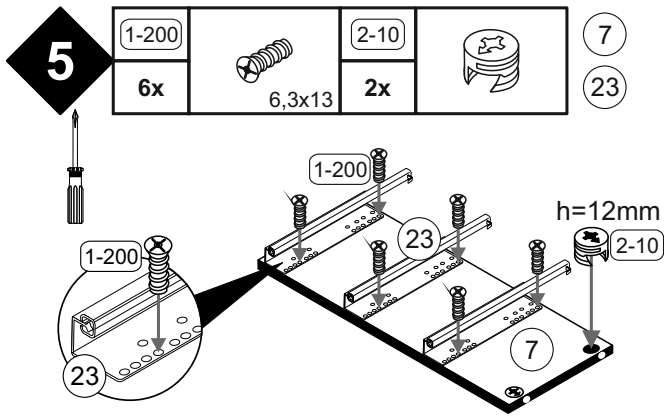
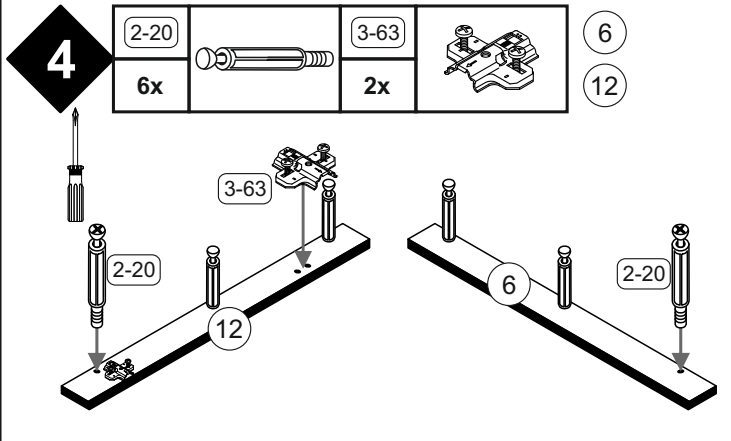
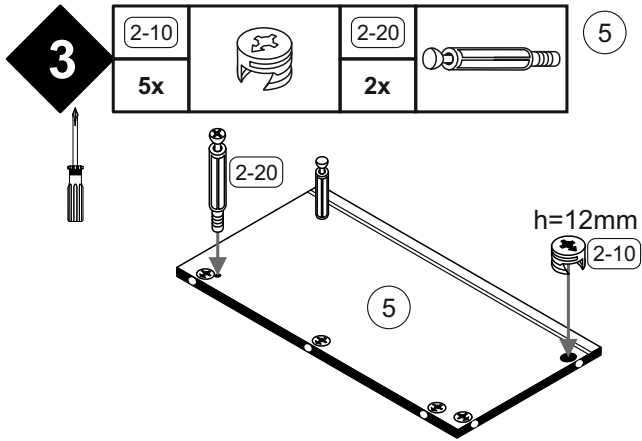
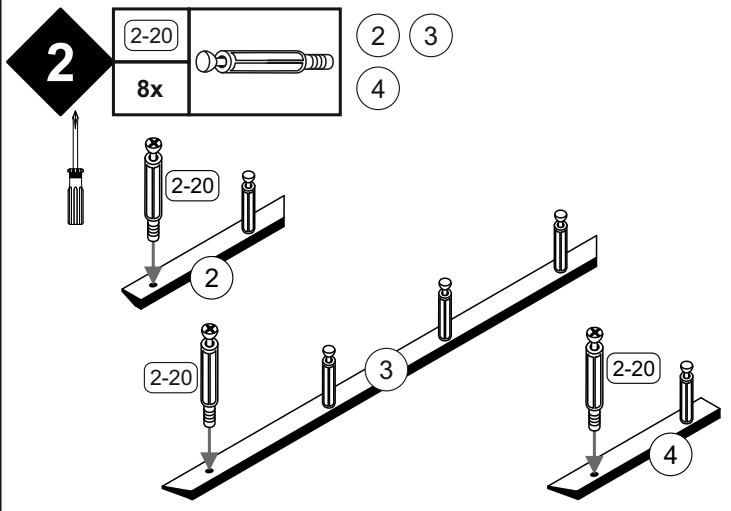
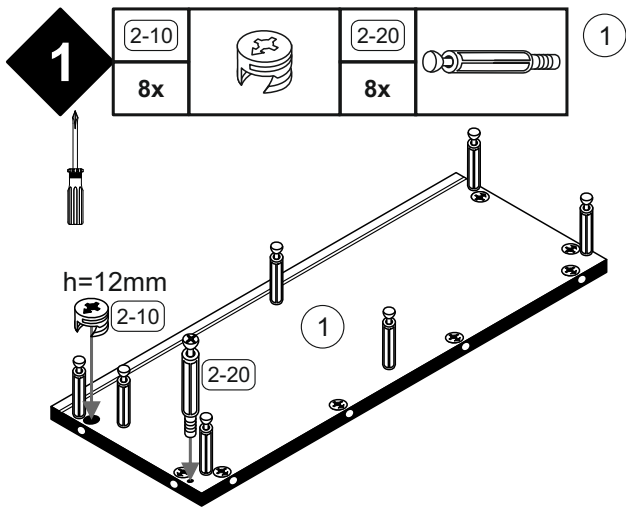

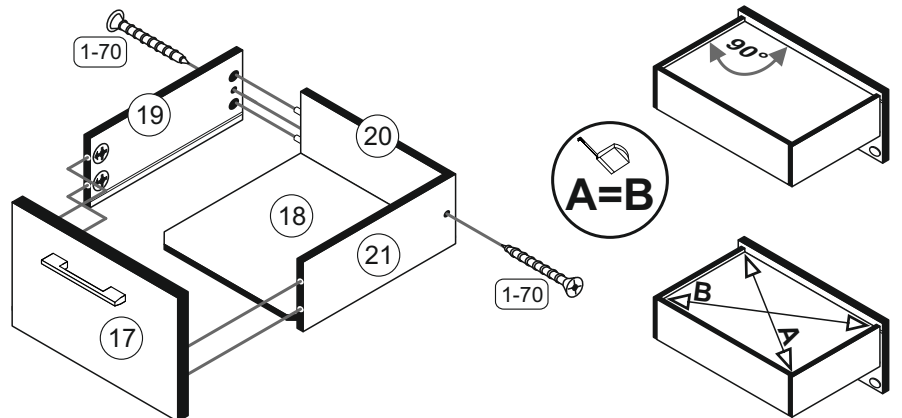
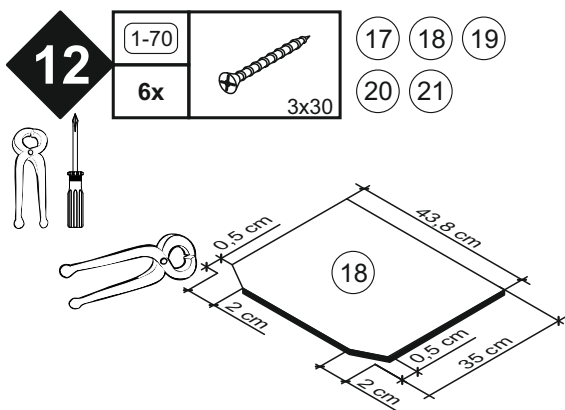
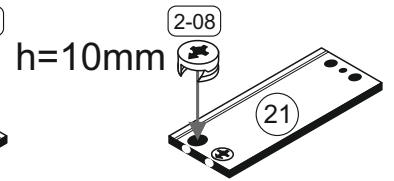
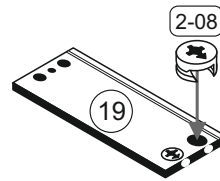
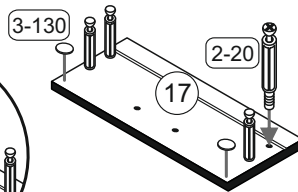
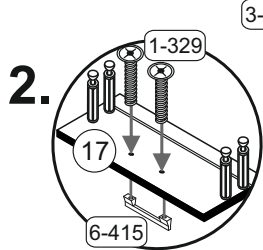
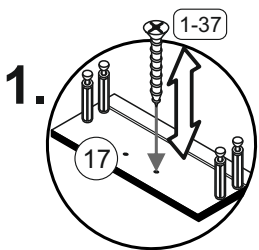
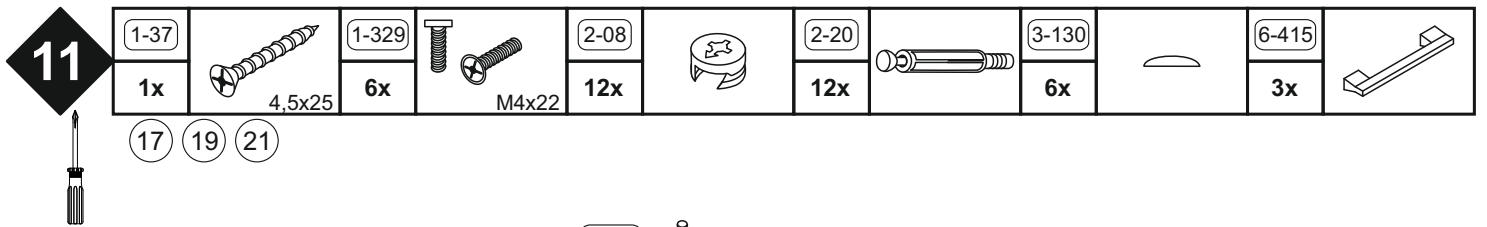
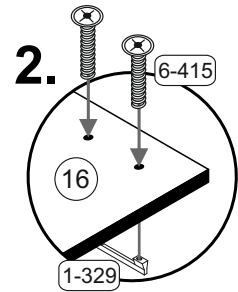
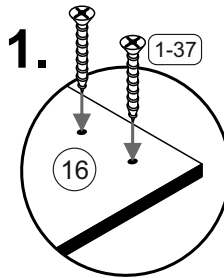
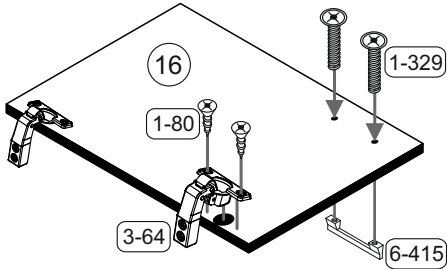
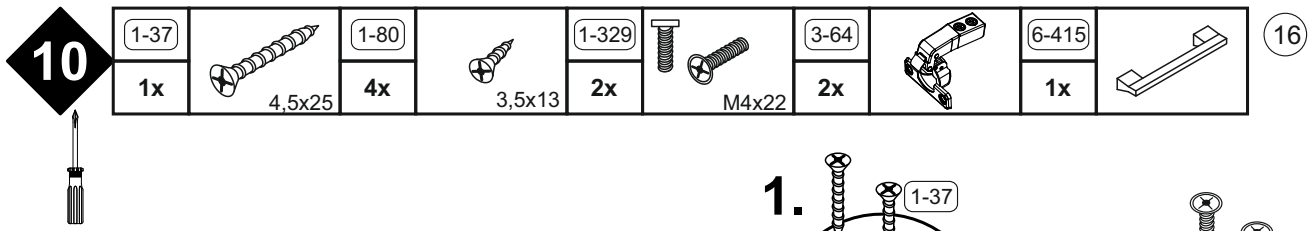
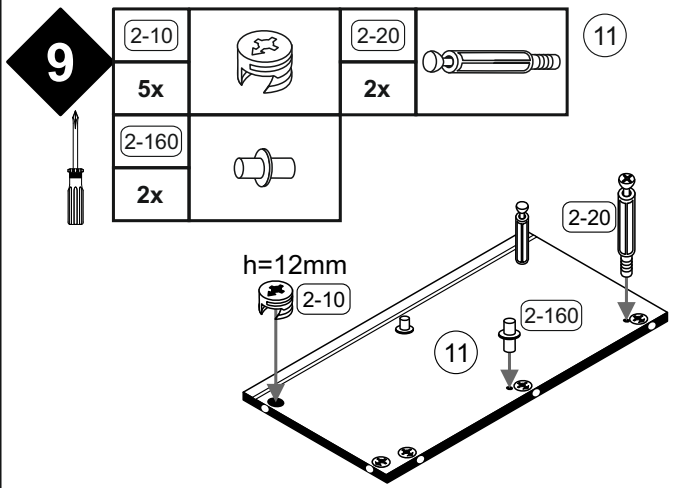
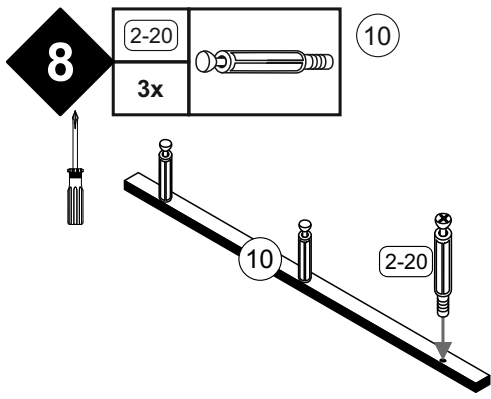



13

1-80		3,5x13
4x		
2-220		
2x		



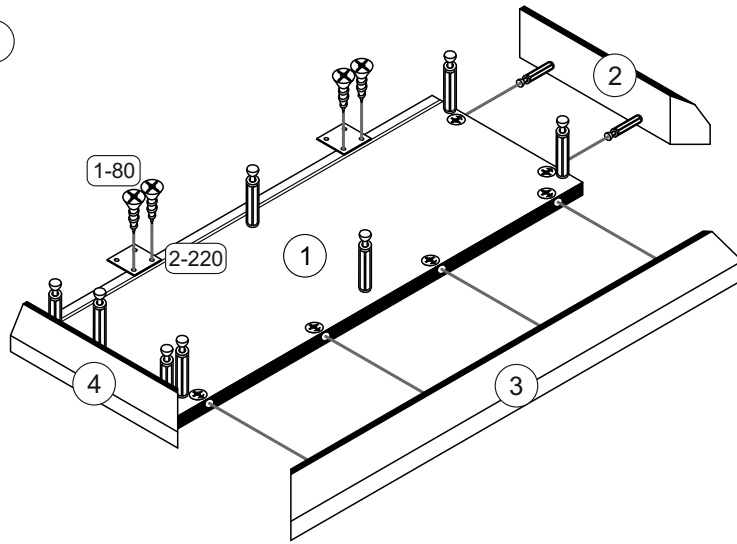



14

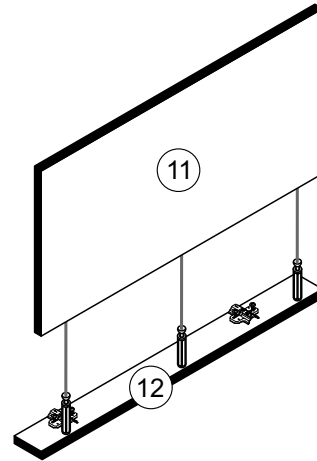
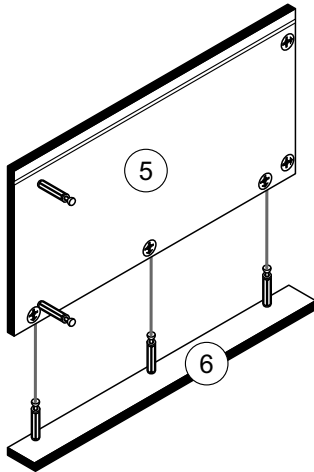

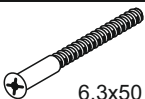

15

1-10		6,3x50
4x		



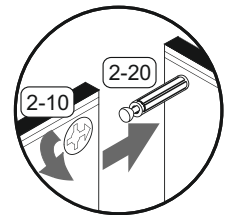
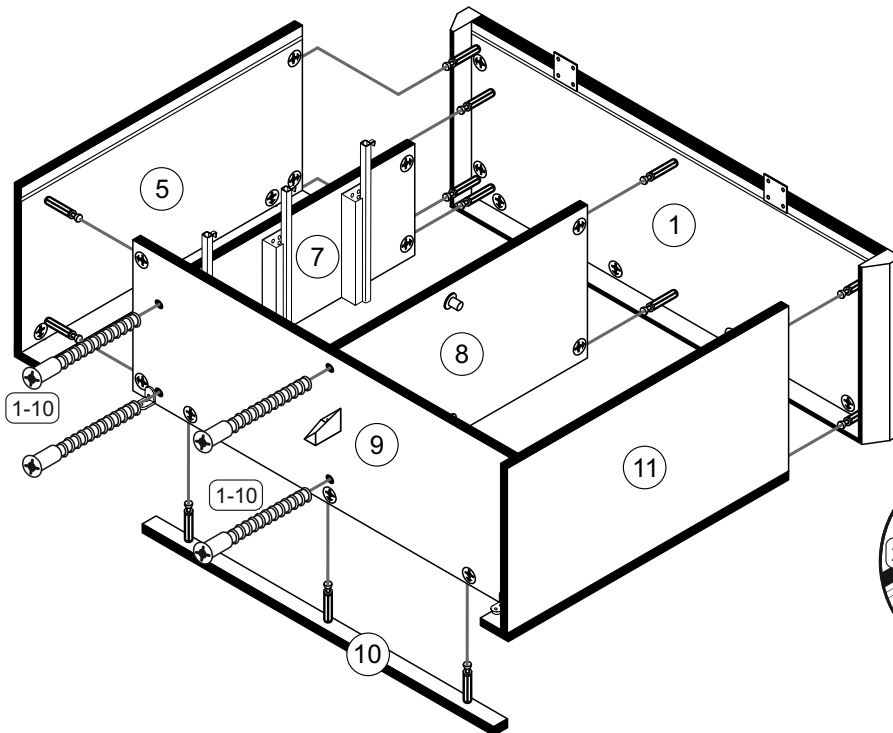

16

1-30		1-90		5-185	
21x	3x16	4x	3.5x20	4x	

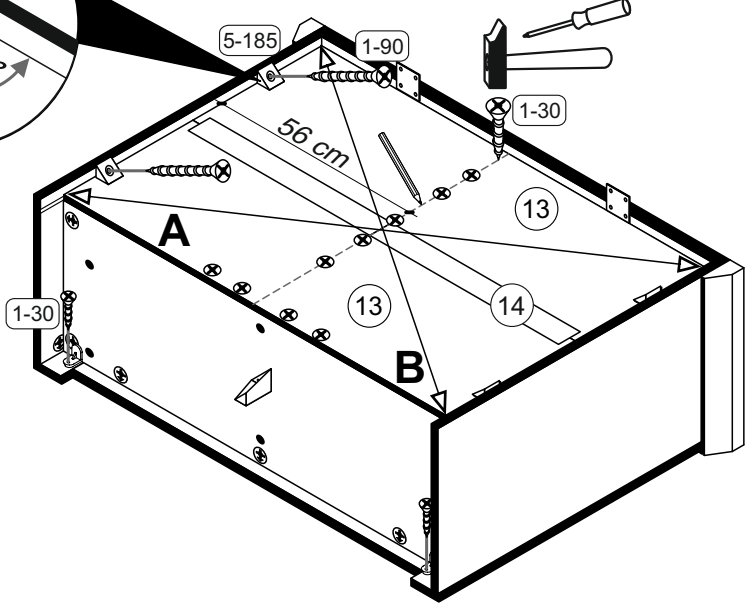
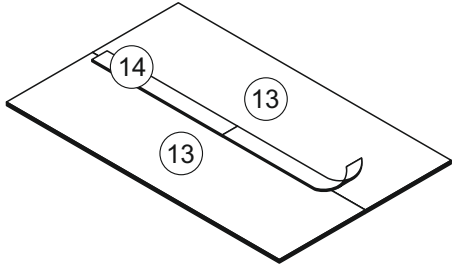
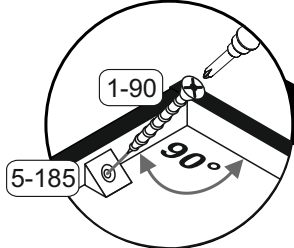
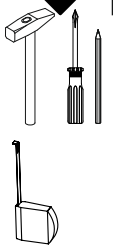

17

1-10		8-80		25	26
8x	6,3x50	1x		27	

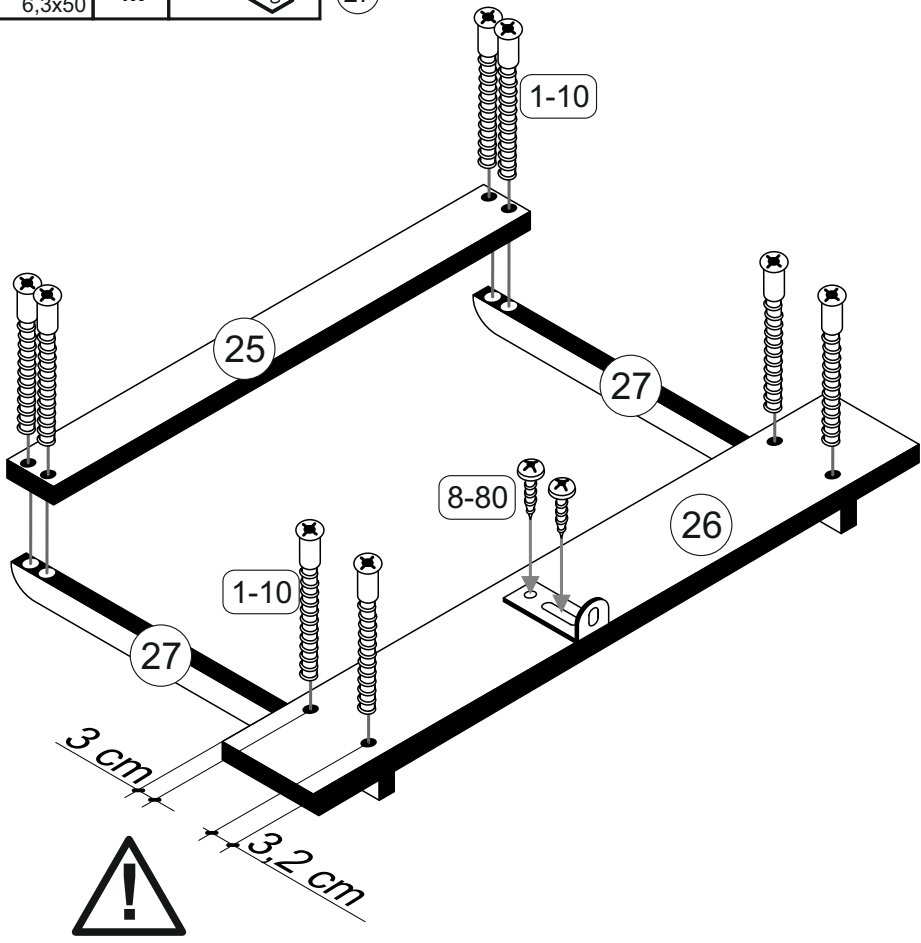

18

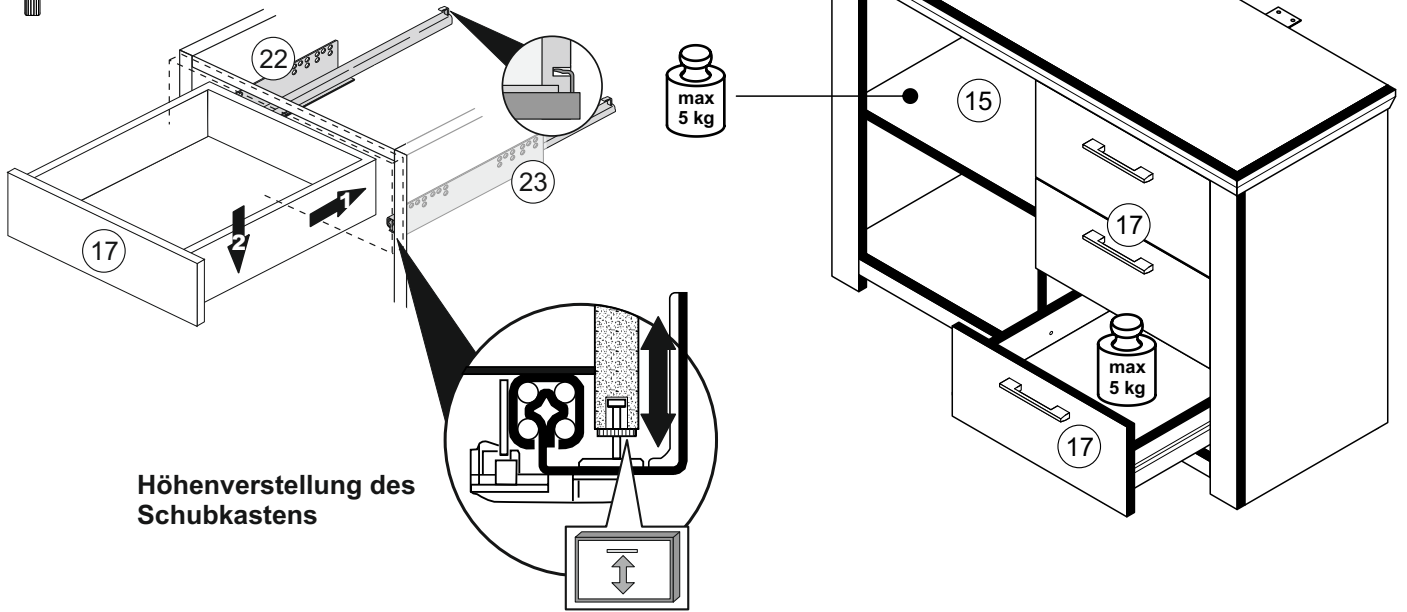

Höhenverstellung des Schubkastens

19



3-07		3-130	
1x		2x	

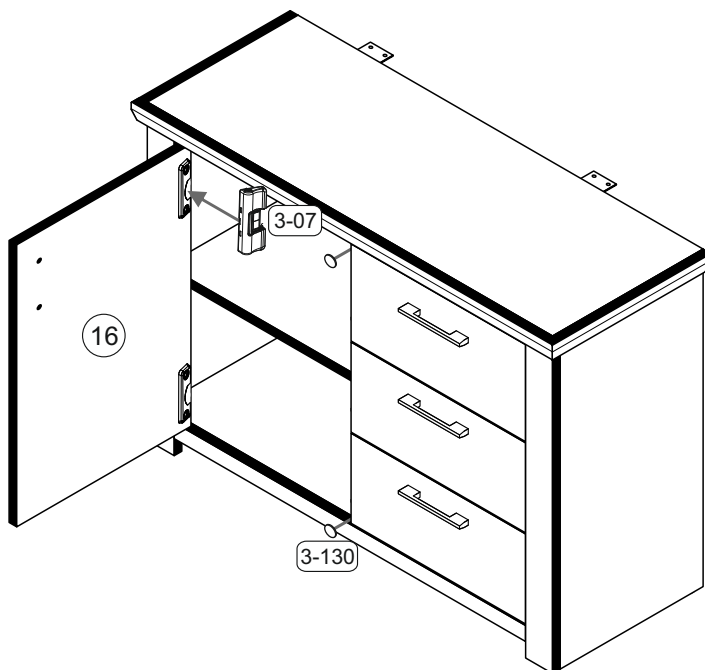

Montage der Tüрдämpfung

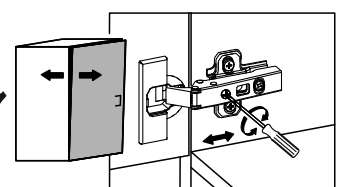
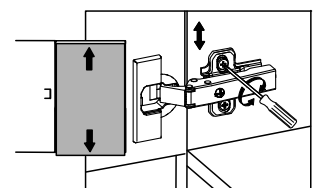
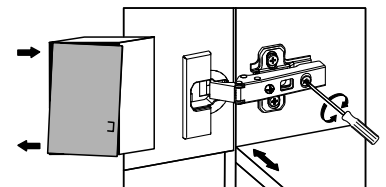
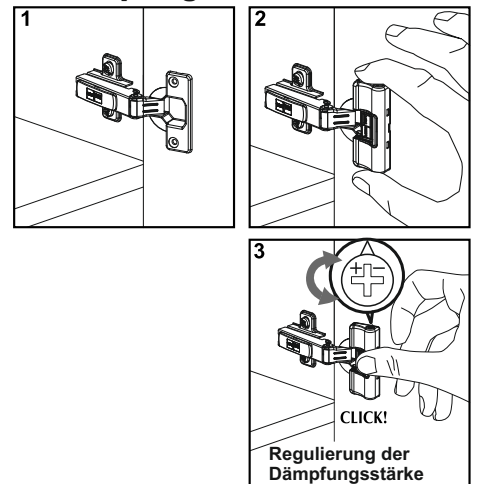

Türen einstellen (Scharniere justieren)

Adjusting the doors (adjusting the hinges)

Régler les portes (ajuster les charnières)

Sistemare le porte (regolare le cerniere)

Deuren instellen (scharnieren afstellen)

Nastawić drzwi (wyregulować zawiasy)

Vyrovnejte dvířka (seřid'te závěsy)

Nastavenie dverí (nastavenie závesov)

Állítsa be az ajtókat (állítsa be a zsanérokot)

Reglare uși (ajustare balamale)

Kapıların ayarlanması (menteşelerin seviye ayarı)

Регулировка дверей (регулировка шарнира)

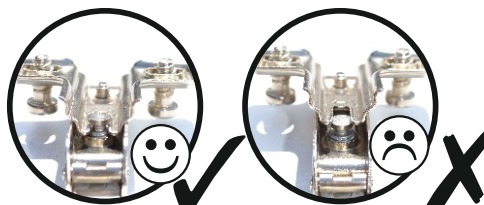

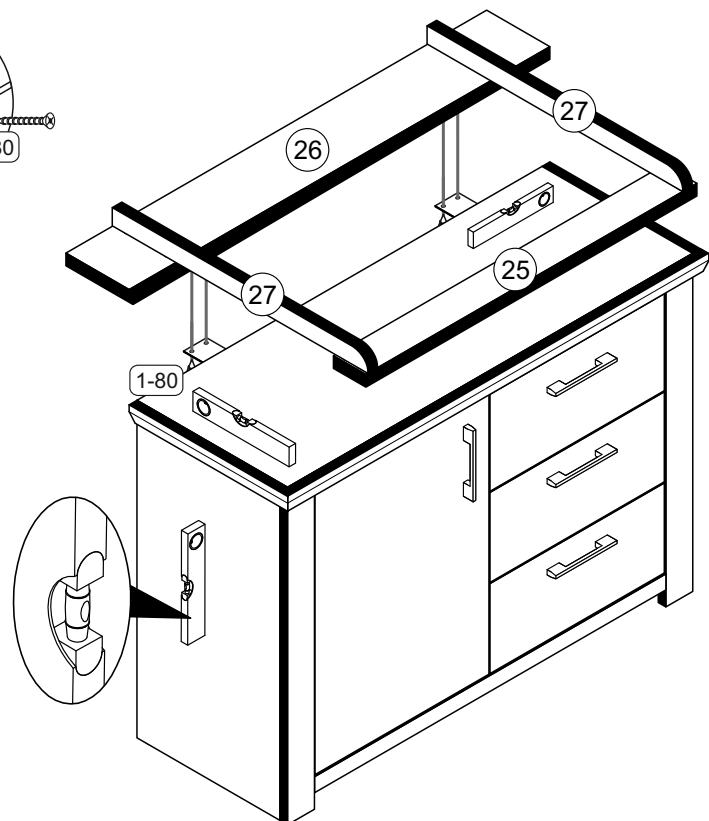
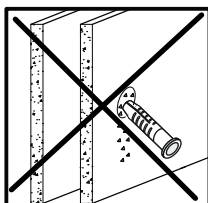
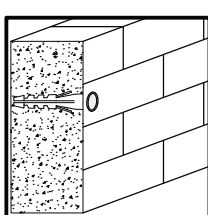
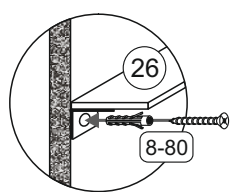
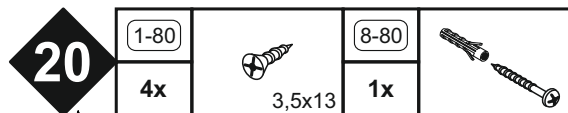

Achtung • Attention • Attenzione • Opgelet • Uwaga • Pozor • Figelem • Atenție • Dikkat • Внимание	
(D)	Wandbefestigung dient als Kippschutz - unbedingt anbringen! Bei einigen Wandtypen kann ein Spezialdübel erforderlich sein!
(GB)	The wall fastening serves to prevent tipping - be absolutely sure to mount it! For certain wall types, a special wall plug may be necessary!
(FR)	La fixation murale sert de protection contre le basculement – à installer impérativement ! Pour certains types de murs il faut des chevilles spéciales !
(TR)	Duvardaki sabitleme, devrilmeye karşı bir emniyet tedbiridir ve mutlaka monte edilmelidir! Bazı duvar tiplerinde bunun için özel bir dübel gerekli olabilir!
(IT)	Il fissaggio alla parete serve da protezione anti-ribaltamento – attaccarla assolutamente! Per alcune strutture di parete può essere necessario un tassello speciale!
(NL)	Bevestiging aan de muur dient als kantelbescherming – zeker en vast bevestigen! Bij enkele muurtypes is een speciale plug misschien vereist!
(RU)	Обязательно установите крепление на стене во избежание опрокидывания! Для некоторых типов стен может потребоваться специальный дюбель!
(CZ)	Montáž na stěnu slouží jako ochrana proti převrnutí – bezpodmínečně umístěte! U některých typů stěn může být zapotřebí speciální hmoždinka!
(HU)	A terméket a falhoz kel rögzíteni, különben az felborulhat! Egyes faltípusoknál speciális tiplít kell használni!
(RO)	Sistemul de fixare la perete servește ca protecție la răsturnare - de montat obligatoriu! Pentru unele tipuri de perți este posibil să fie necesar un diblu special!
(PL)	Mocowanie do ściany jest jednocześnie zabezpieczeniem przed przewróceniem – koniecznie zamontować! Do niektórych rodzajów ścian koniecznie zastosować specjalne kołki mocujące.
(SK)	Upevnenie na stenu slúži ako ochrana proti prevráteniu – bezpodmienečne použite! Pre niektoré druhy stien môže byť potrebná špeciálna hmoždinka!